

# L751



## WINGNUT WITH THREADED STUD

**Material:**  
Reinforced polyamide.  
Oils and greases resistant.

**Surface:**  
Satin.

**Colour:**  
Black (RAL 9011).

**Main Insert:**  
Zinc plated steel threaded stud (tolerance 6g).

### SPECIAL REQUESTS:

- It is possible to supply inserts in different lengths or by special design, on request and for quantities.
- It is possible to supply inserts in different materials, on request and for quantities.
- It is possible to supply colours as shown in the table on page L-31, on request and for quantities.

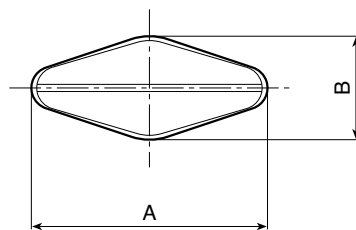
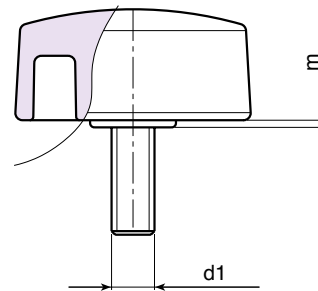
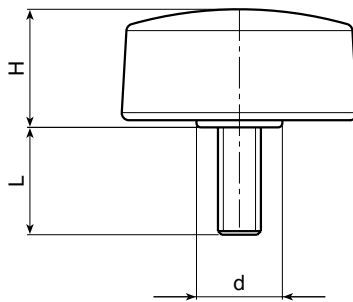

Art.	A	B	H	m	d	LM	d1 6g	Q	g
L75132.TM05X..01	33	15	16,5	1	12	60	M05	16-25-30-40	8-9-11-15
L75132.TM06X..01	33	15	16,5	1	12	60	M06	10-16-20-25-30-40	9-11-12-12-12,5-15,5
L75132.TM08X..01	33	15	16,5	1	12	60	M08	10-16-20-25-30-40	13,5-14,5-16-17,5-19-22
L75148.TM06X..01	48	15	16	1	12,5	70	M06	10-16-20	13-15-16-17
L75148.TM08X..01	48	15	16	1	12,5	70	M08	16-20-25-30-40	18-20-21,5-23-27

Enter the stud length choice in the two .. of the article code. Lengths by request with 150 pieces minimum quantity.

LM = Maximum mouldable length.