

# G795



## KNOB WITH THREADED STUD

**Material:**  
Reinforced polyamide.  
Oils and greases resistant.

**Surface:**  
Satin.

**Colour:**  
Black (RAL 9011).

**Main Insert:**  
Zinc plated steel threaded stud (tolerance 6g).



G

### SPECIAL REQUESTS:

- It is possible to supply inserts in different lengths or by special design, on request and for quantities.
- It is possible to supply inserts in different materials, on request and for quantities.
- It is possible to supply colours as shown in the table on page G-27, on request and for quantities.

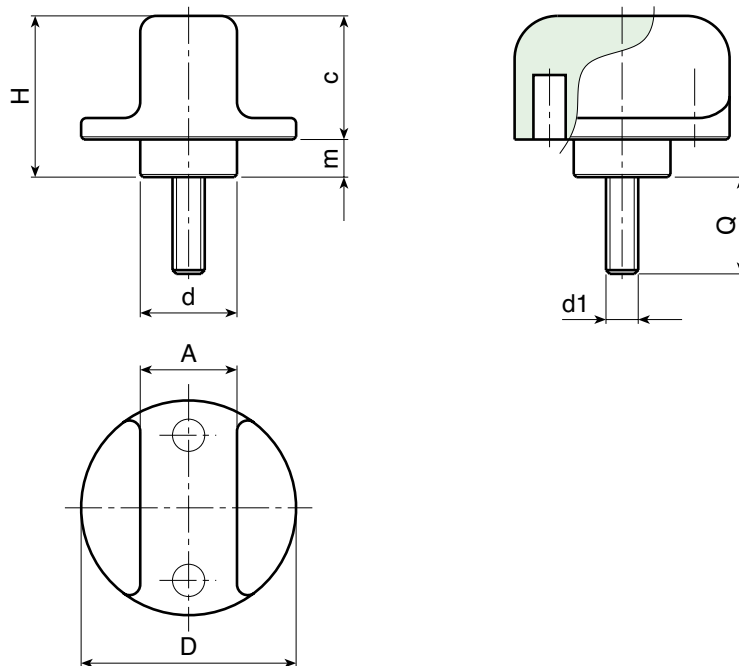

	art.	D	H	d	A	c	m	LM	d1 6g	Q	Δ g
●	G79525.TM05X1601	25	20	12	10	15	5	40	M05	16	12
●	G79525.TM06X3001	25	20	12	10	15	5	40	M06	30	14
●	G79525.TM08X..01	25	20	12	10	15	5	40	M08	A.R.	25
●	G79540.TM08X..01	40	30	18	18	22	7	50	M08	A.R.	40
●	G79540.TM10X3001	40	30	18	18	22	7	50	M10	30	43
●	G79540.TM12X..01	40	30	18	18	22	7	50	M12	A.R.	67

LM = Maximum mouldable length.

It's possible to have different lengths, by customers requests. Minimum 150 pieces.