

G734



4-LOBE HANDWHEEL WITH ELONGATED HUB AND THREADED FEMALE INSERT

Material:
Reinforced polyamide.
Oils and greases resistant.

Surface:
Satin.

Colour:
Black (RAL 9011).

Main Insert:
Brass blind threaded bush (tolerance 6H).



SPECIAL REQUEST:

- It is possible to supply the inserts in different materials, on request and for quantities.
- It's possible to supply the handwheels with hubs by drawing, on request and for quantities.

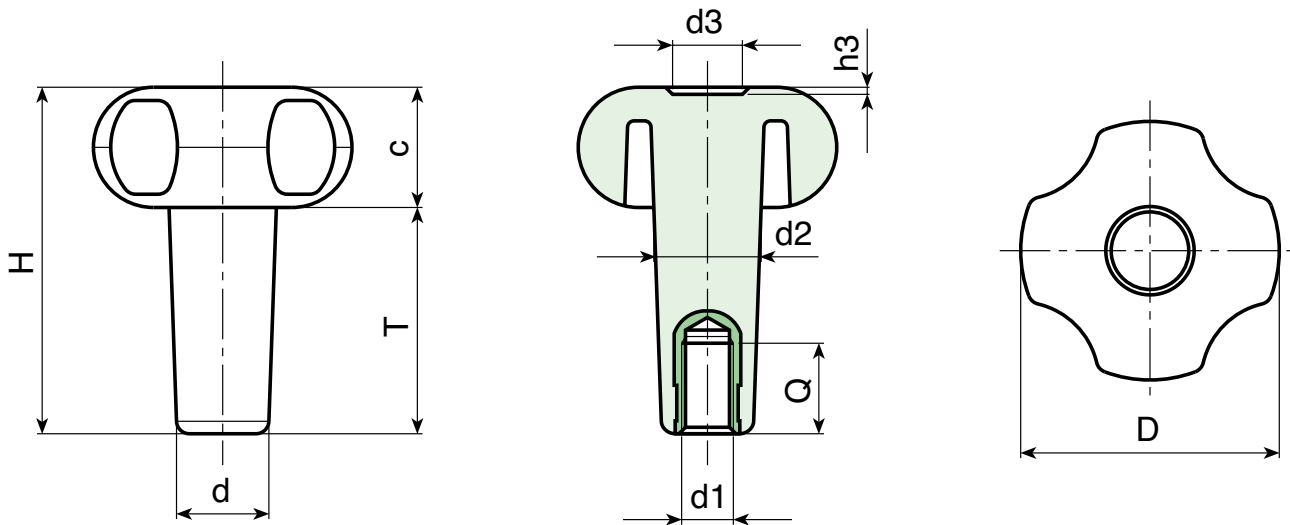

	art.	D	H	T	d	c	d2	d3	h3	d1	Q	g
●	G73430.T25M0601	30	37,5	23,5	13,5	14	14,5	12	2	M06	10	15
●	G73430.T35M0601	30	47	33,5	13,5	14	15	12	2	M06	16	16
●	G73430.T35M0801	30	47	33,5	13,5	14	15	12	2	M08	21	17
●	G73440.T35M1001	41	54	35	16,5	19	17	12	3	M10	15	30
●	G73440.T66M0601	41	85	66	16,5	19	18	12	3	M06	18	35
●	G73450.T40M0801	52	61	39	17,5	22	19	14	2,5	M08	15	47
●	G73450.T40M1001	52	61	39	17,5	22	19	14	2,5	M10	15	49
●	G73450.T50M0801	52	71	49	18	22	20,5	14	2,5	M08	15	55
●	G73450.T50M1001	52	71	49	18	22	20,5	14	2,5	M10	15	56
●	G73450.T60M1001	52	80	58	18	22	21	14	2,5	M10	15	62
●	G73460.T60M0801	59	83	58	23	25	24	24	4	M08	21	91
●	G73460.T60M1001	59	83	58	23	25	24	24	4	M10	15	91
●	G73460.T60M1201	59	83	58	23	25	24	24	4	M12	21	96
●	G73460.T80M0801	59	103	78	23	25	24	24	4	M08	21	105
●	G73460.T80M1001	59	103	78	23	25	24	24	4	M10	15	104
●	G73460.T80M1201	59	103	78	23	25	24	24	4	M12	21	107