

F186



SOLID CROSS HANDWHEEL WITH FEMALE THREADED INSERT

Material:
Reinforced polyamide.
Oils and greases resistant.

Surface:
Satin.

Colour:
Black (RAL 9011).

Main Insert:
Brass blind threaded bush (tolerance 6H).



SPECIAL REQUEST:

- It is possible to supply the inserts in different materials, on request and for quantities.
- It is possible to supply colours as shown in the table at pag. F-45, on request and for quantities.

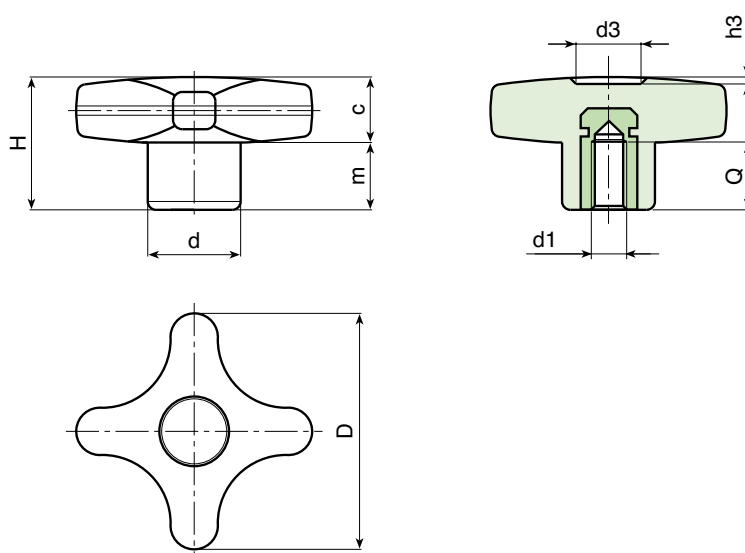

SSZF	Art.	D	H	d	c	m	d3	h3	d1 6H	Q	g
●	F18632.TM0401	32	23	15	11	12	11	1,5	M04	7	11
●	F18632.TM0501	32	23	15	11	12	11	1,5	M05	14	11,5
●	F18632.TM0601	32	23	15	11	12	11	1,5	M06	10	12
●	F18632.TM0801	32	23	15	11	12	11	1,5	M08	14	12,5
●	F18632.TM1001	32	23	15	11	12	11	1,5	M10	14	13
●	F18640.TM0501	40	24,5	16	12	12,5	13	1,5	M05	14	14
●	F18640.TM0601	40	24,5	16	12	12,5	13	1,5	M06	16	15
●	F18640.TM0801	40	24,5	16	12	12,5	13	1,5	M08	14	16
●	F18640.TM1001	40	24,5	16	12	12,5	13	1,5	M10	14	17
●	F18650.TM0601	50	29	20	14	15	14	2	M06	16	25
●	F18650.TM0801	50	29	20	14	15	14	2	M08	14	26
●	F18650.TM1001	50	29	20	14	15	14	2	M10	14	27
●	F18650.TM1201	50	29	20	14	15	14	2	M12	18	29
●	F18660.TM0801	60	34	24	15,5	18,5	18	2	M08	19	40
●	F18660.TM1001	60	34	24	15,5	18,5	18	2	M10	21	43
●	F18660.TM1201	60	34	24	15,5	18,5	18	2	M12	18	44
●	F18660.TM1401	60	34	24	15,5	18,5	18	2	M14	19	47