

F178



SOLID 6 LOBE HANDWHEEL WITH MALE THREADED STUD

Material:
Reinforced polyamide.
Oils and greases resistant.

Surface:
Satin.

Colour:
Black (RAL 9011).

Main Insert:
Zinc plated steel threaded stud (tolerance 6g).

SPECIAL REQUESTS:

- It is possible to supply inserts in different lengths or by special design, on request and for quantities.
- It is possible to supply inserts in different materials, on request and for quantities.
- It is possible to supply colours as shown in the table on page F-45, on request and for quantities.

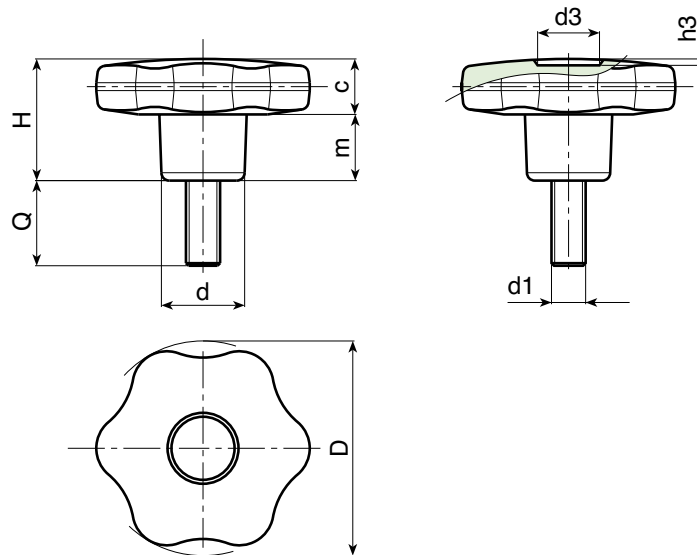

Art.	D	H	d	c	m	d3	h3	LM	d1 6g	Q	Δ g
F17830.TM05X..01	30	22	15	11	11	9	1,5	80	M05	10-16-20-30-40	13-14-15-16-17
F17830.TM06X..01	30	22	15	11	11	9	1,5	80	M06	10-16-20 25-30-40	15-16-17 17,5-18-19
F17830.TM08X..01	30	22	15	11	11	9	1,5	80	M08	16-20-30-40	19-21-25-28
F17830.TM10X..01	30	22	15	11	11	9	1,5	80	M10	20-30-40	28-33-39
F17840.TM06X..01	40	24,5	17	12	12,5	12	1	130	M06	16-20-30-40	25-25-27-28
F17840.TM08X..01	40	24,5	17	12	12,5	12	1	130	M08	16-20-25-30 35-40-45-50	28-30-31-33 34-36-38-39
F17840.TM10X..01	40	24,5	17	12	12,5	12	1	130	M10	20-30-40-50	37-41-45-49
F17850.TM08X..01	50	29	20	14	15	14,5	1,5	130	M08	15-20-30-40	48-49-52-55
F17850.TM10X..01	50	29	20	14	15	14,5	1,5	130	M10	20-25-30-40-50	55-57-60-61-64
F17850.TM12X..01	50	29	20	14	15	14,5	1,5	130	M12	20-30-40-50	63-67-72-77
F17860.TM08X..01	60	34	24	16	18	18	1,5	130	M08	30-40	71-74
F17860.TM10X..01	60	34	24	16	18	18	1,5	130	M10	20-30-40-50	74-80-85-88
F17860.TM12X..01	60	34	24	16	18	18	1,5	130	M12	20-30-40-50	95-102-109-116
F17860.TM14X..01	60	34	24	16	18	18	1,5	130	M14	A.R.	-

Enter the stud length choice in the two .. of the article code. Lengths by request with 150 pieces minimum quantity.

LM = Maximum mouldable length.

A.R. = By request. Minimum order quantity 150.

Presumable presence in the stock in %

90% ● 40% ● 5% ●

