

F175



SOLID 6 LOBE HANDWHEEL WITH FEMALE THREADED INSERT

Material:
Reinforced polyamide.
Oils and greases resistant.

Surface:
Satin.

Colour:
Black (RAL 9011).

Main Insert:
Brass blind threaded bush (tolerance 6H).



SPECIAL REQUEST:

- It is possible to supply the inserts in different materials, on request and for quantities.
- It is possible to supply colours as shown in the table at pag. F-45, on request and for quantities.

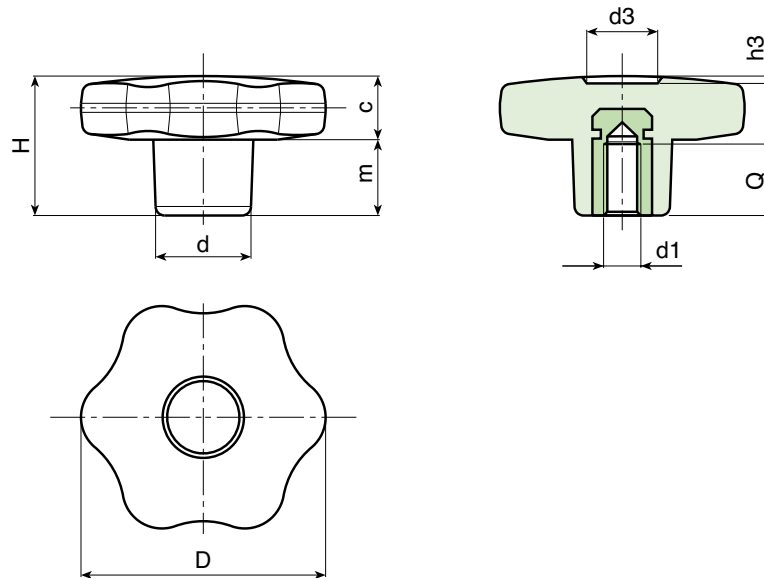

Art.	D	H	d	c	m	d3	h3	d1 6H	Q	g
F17530.TM0401	30	22	15	11	11	9	1,5	M04	7	11,5
F17530.TM0501	30	22	15	11	11	9	1,5	M05	14	11,5
F17530.TM0601	30	22	15	11	11	9	1,5	M06	10	12
F17530.TM0801	30	22	15	11	11	9	1,5	M08	14	13,5
F17530.TM1001	30	22	15	11	11	9	1,5	M10	14	14
F17540.TM0501	40	24,5	17	12	12,5	12	1	M05	14	22
F17540.TM0601	40	24,5	17	12	12,5	12	1	M06	16	22
F17540.TM0801	40	24,5	17	12	12,5	12	1	M08	14	21,5
F17540.TM1001	40	24,5	17	12	12,5	12	1	M10	14	21
F17550.TM0601	50	29	20	14	15	14,5	1,5	M06	16	36
F17550.TM0801	50	29	20	14	15	14,5	1,5	M08	14	36
F17550.TM1001	50	29	20	14	15	14,5	1,5	M10	14	37
F17550.TM1201	50	29	20	14	15	14,5	1,5	M12	18	39
F17560.TM0801	60	34	24	16	18	18	1,5	M08	19	59
F17560.TM1001	60	34	24	16	18	18	1,5	M10	21	59
F17560.TM1201	60	34	24	16	18	18	1,5	M12	18	62
F17560.TM1401	60	34	24	16	18	18	1,5	M14	19	63