

B226



FIXED HANDLE WITH THREADED INSERT

Material:
Reinforced polyamide.
Oils and greases resistant.

Surface:
Satin.

Colour:
Black (RAL 9011).

Main Insert:
Brass blind threaded bush (tolerance 6H).

SPECIAL REQUEST:

- It is possible to supply the inserts in different materials, on request and for quantities.
- It is possible to supply colours as shown in the table at pag. B-35, on request and for quantities.

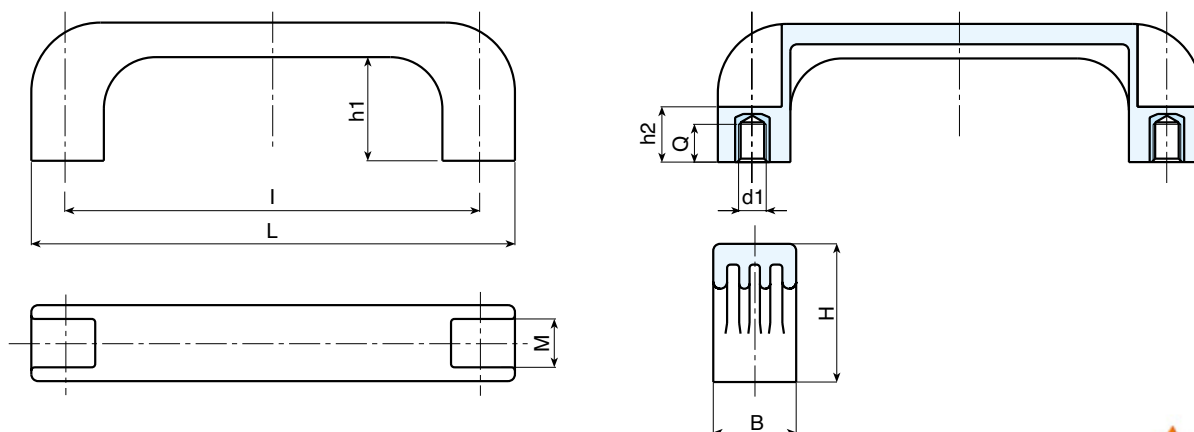

Art.	L	I	B	M	H	h1	h2	Q	d1	Δ g	F1 (N)	F2 (N)
B226094.TM0501	110	94	21	13	37	29	13	7	M05	23	4300	1300
B226094.TM0601	110	94	21	13	37	29	13	7	M06	23	4300	1300
B226117.TM0501	140	117	24	13	40	29	15	10	M05	43	4100	2800
B226117.TM0601	140	117	24	13	40	29	15	9	M06	43	4100	2800
B226117.TM0801	140	117	24	13	40	29	15	9	M08	43	4100	2800
B226120.TM0501	140	120	24	14	40	29	15	10	M05	43	6100	2800
B226120.TM0601	140	120	24	14	40	29	15	9	M06	43	6100	2800
B226120.TM0801	140	120	24	14	40	29	15	9	M08	43	6100	2800
B226132.TM0501	151	132	26	14	43	31	16	10	M05	70	7300	3500
B226132.TM0601	151	132	26	14	43	31	16	9	M06	70	7300	3500
B226132.TM0801	151	132	26	14	43	31	16	9	M08	70	3700	2800
B226180.TM0601	200	180	28	17	51	39	21	14	M06	87	3700	2800
B226180.TM0801	200	180	28	17	51	39	21	14	M08	88	3700	2800
B226235.TM0801	262	235	32	20	53	40	21	14	M08	123	4300	3200
B226235.TM1001	262	235	32	20	53	40	21	14	M10	123	4300	3200