

A523



CLAMPING LEVER WITH MALE THREADED STUD

Material:

Special high resistance glass fiber reinforced technopolymer.
Oils and greases resistant.

Surface:

Satin.

Lever body and insert colour:

Black (RAL 9011).

Main insert:

Zinc plated steel threaded stud.
(Thread tolerance 6g).

Fixing screw:

Black-oxide treated steel screw with slotted head.

Spring:

Stainless steel spring (AISI 302).



SPECIAL REQUESTS:

- It's possible to supply the inserts with different lengths, on request and for quantities.
- It's possible to supply the inserts with different materials, on request and for quantities.
- It's possible to supply the lever body with colours as shown in the table at page A-31, on request and for quantities.

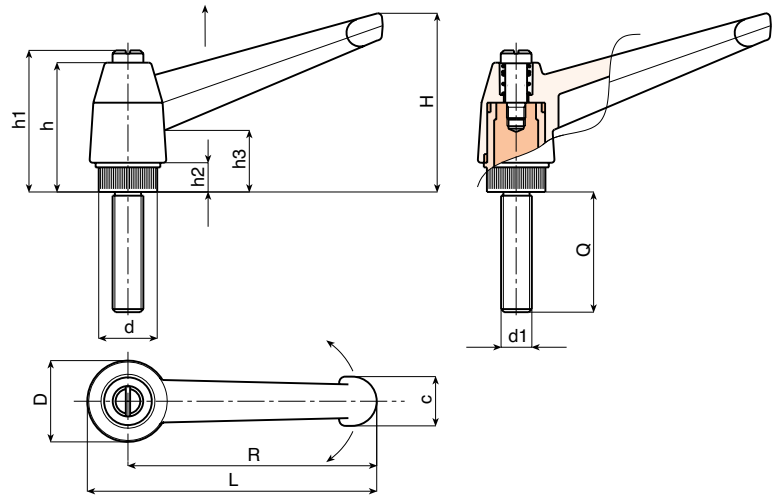

Art.	L	R	H	D	d	c	h	h1	h2	h3	LM	d1 6g	Q	⚖ g
A523043.TM04X..01	52	43	33	17	11,5	11	27	30	6	14	60	M04	10-16-20-25-30-40	16-16-17-18-18-19
A523043.TM05X..01	52	43	33	17	11,5	11	27	30	6	14	60	M05	10-16-20-25-30-40	16-17-17-17-18-19
A523043.TM06X..01	52	43	33	17	11,5	11	27	30	6	14	60	M06	10-16-20-25-30-40	18-18-19-20-20-21
A523065.TM06X..01	77	65	45	23	15	13	34	38	8	17	60	M06	16-20-25-30-40	33-34-35-37
A523065.TM08X..01	77	65	45	23	15	13	34	38	8	17	60	M08	16-20-25-30-35 40-45-50	35-37-38-40-42 43-44-46
A523083.TM08X..01	97	83	57	27	19	16	43	47	10	23	90	M08	20-25-30-35 40-50-60	58-59-61-62 64-67-70
A523083.TM10X..01	97	83	57	27	19	16	43	47	10	23	90	M10	20-25-30-35 40-50-60	67-70-72-74 77-82-87
A523083.TM12X..01	97	83	57	27	19	16	43	47	10	23	90	M12	20-25-30-35 40-50-60	79-82-86-89 93-100-107
A523104.TM10X..01	121	104	70	33	24	19	50	53	11	26	90	M10	20-30-40-50-60	109-114-119-124-129
A523104.TM12X..01	121	104	70	33	24	19	50	53	11	26	90	M12	20-30-40-50-60	115-122-129-136-143
A523104.TM14X..01	121	104	70	33	24	19	50	53	11	26	90	M14	30-40-50-60-70	140-150-160-170-180
A523104.TM16X..01	121	104	70	33	24	19	50	53	11	26	90	M16	30-40-50-60-70	156-170-184-198-212

Enter the stud length choice in the two .. of the article code. Lengths by request with 100 pieces minimum quantity.

LM = Maximum mouldable length.

Presumable presence in the stock in %

90% ● 40% ● 5% ●