

A522



CLAMPING LEVER WITH FEMALE THREADED INSERT

Material:

Special high resistance glass fiber reinforced technopolymer. Oils and greases resistant.

Surface:

Satin.

Lever body and insert colour:

Black (RAL 9011).

Main insert:

Zinc plated steel insert with threaded blind bore. (Thread tolerance 6H).

Fixing screw:

Black-oxide treated steel screw with slotted head.

Spring:

Stainless steel spring (AISI 302).

SPECIAL REQUESTS:

- It's possible to supply the inserts with different materials, on request and for quantities.
- It's possible to supply the lever body with colours as shown in the table at page A-31 on request and for quantities.

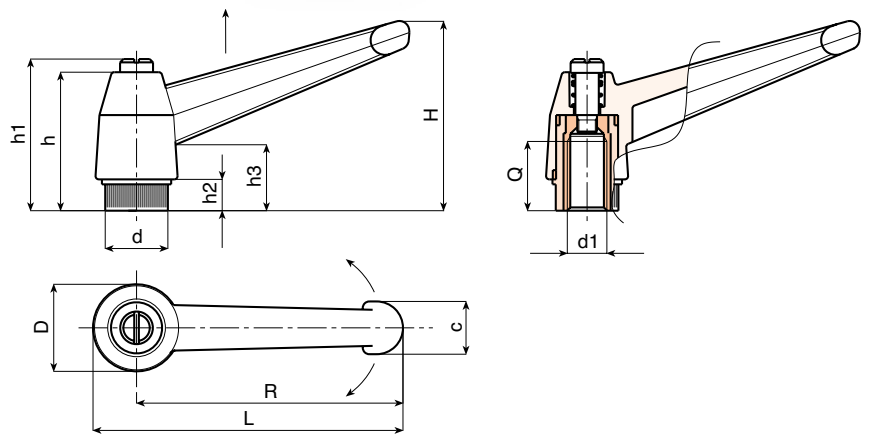

Art.	L	R	H	D	d	c	h	h1	h2	h3	d1 6H	Q	g
A522043.TM0401	52	43	33	17	11,5	11	27	30	6	14	M04	10	14
A522043.TM0501	52	43	33	17	11,5	11	27	30	6	14	M05	9	14
A522043.TM0601	52	43	33	17	11,5	11	27	30	6	14	M06	9	14
A522065.TM0601	77	65	45	23	15	13	34	38	8	17	M06	15	28
A522065.TM0801	77	65	45	23	15	13	34	38	8	17	M08	15	26
A522065.TM1001	77	65	45	23	15	13	34	38	8	17	M10	13	28
A522083.TM0801	97	83	57	27	19	16	43	47	10	23	M08	17	52
A522083.TM1001	97	83	57	27	19	16	43	47	10	23	M10	17	48
A522083.TM1201	97	83	57	27	19	16	43	47	10	23	M12	16	48
A522104.TM1001	121	104	70	33	24	19	50	53	11	26	M10	20	114
A522104.TM1201	121	104	70	33	24	19	50	53	11	26	M12	22	106
A522104.TM1401	121	104	70	33	24	19	50	53	11	26	M14	21	100
A522104.TM1601	121	104	70	33	24	19	50	53	11	26	M16	23	100